

# Morphological selection in an extreme flow environment: body shape and waterfall-climbing success in the Hawaiian stream fish *Sicyopterus stimpsoni*

Richard W. Blob,<sup>1,\*</sup> William C. Bridges,<sup>†</sup> Margaret B. Ptacek,<sup>\*</sup> Takashi Maie,<sup>\*</sup> Roberto A. Cediell,<sup>‡</sup> Morgan M. Bertolas,<sup>‡</sup> Matthew L. Julius<sup>‡</sup> and Heiko L. Schoenfuss<sup>‡</sup>

<sup>\*</sup>Department of Biological Sciences, Clemson University, Clemson, SC, 29634, USA; <sup>†</sup>Department of Applied Economics and Statistics, Clemson University, Clemson, SC, 29634, USA; <sup>‡</sup>Department of Biological Sciences, St Cloud State University, Wick Science Center, St Cloud, MN, 56301, USA

**Synopsis** Flow characteristics are a prominent factor determining body shapes in aquatic organisms, and correlations between body shape and ambient flow regimes have been established for many fish species. In this study, we investigated the potential for a brief period of extreme flow to exert selection on the body shape of juvenile climbing Hawaiian gobiid fishes. Because of an amphidromous life history, juvenile gobies that complete an oceanic larval phase return to freshwater habitats, where they become adults. Returning juveniles often must scale waterfalls (typically with the use of a ventral sucker) in order to reach the habitats they will use as adults, thereby exposing these animals to brief periods of extreme velocities of flow. Hydrodynamic theory predicts that bodies with larger suckers and with lower heights that reduce drag would have improved climbing success and, thus, be well suited to meet the demands of the flows in waterfalls. To test the potential for the flow environment of waterfalls to impose selection that could contribute to differences in body shape between islands, we subjected juvenile *Sicyopterus stimpsoni* to climbing trials up artificial waterfalls (~100 body lengths) and measured differences in body shape between successful and unsuccessful climbers. Waterfalls appear to represent a significant selective barrier to these fishes, as nearly 30% failed our climbing test. However, the effects of selection on morphology were not straightforward, as significant differences in shape between successful and unsuccessful climbers did not always match hydrodynamic predictions. In both selection experiments and in adult fish collected from habitats with different prevailing conditions of flow (the islands of Hawai'i versus Kaua'i), lower head heights were associated with exposure to high-flow regimes, as predicted by hydrodynamic theory. Thus, a premium appears to be placed on the reduction of drag via head morphology throughout the ontogeny of this species. The congruence of phenotypic selection patterns observed in our experiments, with morphological character divergence documented among adult fish from Hawai'i and Kaua'i, suggests that differences in morphology between subpopulations of adult climbing gobies may result, at least in part, from the selective pressures of high-velocity flows encountered by migrating juveniles.

## Introduction

Aquatic habitats present diverse challenges to their inhabitants. Prominent among these is the diversity in rates of flow, with fast flows subjecting animals to distinct physical demands (Daniel and Webb 1987; Denny 1993; Vogel 1994) that are frequently accommodated by morphological specializations, including many of the locomotory system (Webb 1984, 1988; Maie et al. 2007; Rivera 2008). For example, numerous studies have shown that fish living in faster flows show body shapes better suited to reduce drag than do those in habitats with slower flows (Walker 1997; Domenici 2003; Langerhans et al. 2003). In addition, laboratory studies have shown

that juvenile brook charr reared in high-velocity environments had larger maximum caudal fin heights and deeper caudal peduncles than did fish reared in low-velocity environments (Imre et al. 2002), and fish reared in high-velocity environments also had shorter pectoral fins (Peres-Neto and Magnan 2004). Thus, laboratory and field studies indicate that the sustained physical demands of living in fast water can be associated with changes in the body form of fish (Pakkasmaa and Piironen 2001; Brinsmead and Fox 2002; McGuigan et al. 2003).

Although the potential impact of sustained flow on locomotor morphology has been demonstrated in fish, some habitats exhibit extreme conditions of

From the symposium "Going with the Flow: Ecomorphological Variation across Aquatic Flow Regimes" presented at the annual meeting of the Society for Integrative and Comparative Biology, January 2–6, 2008, at San Antonio, Texas.

<sup>1</sup>E-mail: rblob@clemson.edu

*Integrative and Comparative Biology*, volume 48, number 6, pp. 734–749

doi:10.1093/icb/icn086

Advanced Access publication September 23, 2008

© The Author 2008. Published by Oxford University Press on behalf of the Society for Integrative and Comparative Biology. All rights reserved. For permissions please email: journals.permissions@oxfordjournals.org.

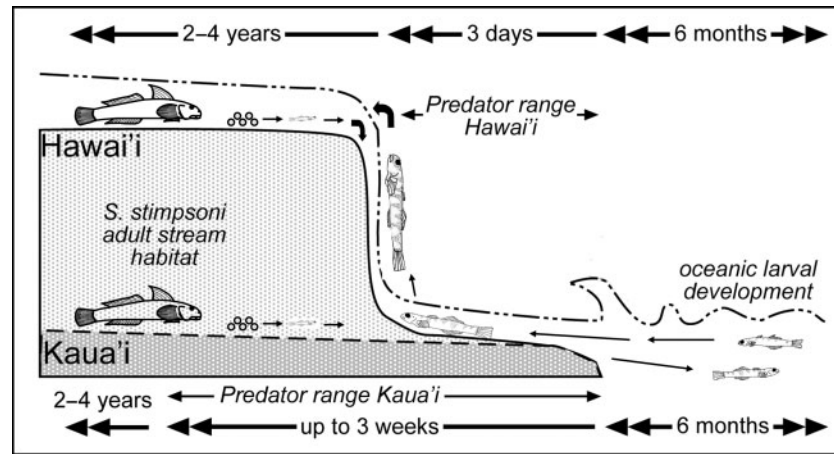

**Fig. 1** Schematic illustration of the life cycle of *S. stimpsoni* on the islands of Hawai'i (top) and Kaua'i (bottom). Adults live upstream (left side of figure) on both islands. Larvae hatching from eggs (circles) are flushed downstream to the ocean (right side of figure). Juveniles return to streams after about 6 months, which on Hawai'i requires scaling of substantial waterfalls. Because predatory *E. sandwicensis* cannot climb, the nearshore waterfalls on Hawai'i shorten the range over which incoming juveniles are exposed to predators to ~3 days (time scale at top of figure). In contrast, on Kaua'i, lower gradient streams do not require the climbs required on Hawai'i, but instead lengthen incoming juvenile exposure to predators to up to 3 weeks (time scale at bottom of figure).

flow only briefly or over short geographic segments (Fitzsimons and Nishimoto 1995). These extreme flow regimes may have to be traversed during migration and could present brief, but intense, periods of selection that could favor specific morphologies. Studying these discrete selective pressures and their effects on body shape could help clarify the significance of such brief events and their potential to drive adaptation. An example of brief exposure to extreme flow is found during the amphidromous migration of gobioid fishes in the Hawaiian Islands. Freshwater goby hatchlings are swept to the ocean to develop for several months before returning to streams (Fig. 1; Radtke et al. 1988). For *Sicyopterus stimpsoni*, *Lentipes concolor*, and *Awaous guamensis*, the habitats of adults often are above waterfalls tens of meters (as much as 30,000 body lengths) tall (Fig. 1; Schoenfuss and Blob 2003). Juveniles readily climb these falls, thereby not only reaching the habitat of adults, but also escaping from the range of the only native piscivorous fish, *Eleotris sandwicensis*, which cannot climb (Fitzsimons et al. 1997; Schoenfuss and Blob 2007). Climbing exposes these juvenile gobies to extreme flow for a brief, but critical, period of their lifespan. Despite large numbers of oceanic juveniles returning daily to the streams, adults are not very numerous in upstream reaches (Nishimoto and Kuamo'o 1997). Thus, it is likely that traversing waterfalls is crucial in determining survival and ultimate reproductive success of incoming juveniles (Blob et al. 2006). Could such a brief episode of exposure to extreme flow be sufficient to select for specific morphologies among

surviving juveniles, and might such features be maintained into adulthood?

*Sicyopterus stimpsoni* is particularly well-suited to study the effects of extreme flow on body shape as it is the only obligate algal grazer among Hawaiian freshwater gobies (Kido 1996, 1997; Julius et al. 2005; Julius 2007) and has minimal interactions with other species of gobies in streams (Tate 1997; Fitzsimons et al. 2003). This likely reduces the significance of other selective pressures, such as interspecific competition. *Sicyopterus stimpsoni* "inches up" through flowing water by alternating advancement of two ventral suckers that adhere to the substrate: a pelvic disc formed from fusion of the pelvic fins (common to gobioid fishes), and an oral disc formed by skin over the upper jaw and an internal velum (Schoenfuss et al. 1997; Nishimoto and Fitzsimons 1999; Schoenfuss and Blob 2003). Although adult *S. stimpsoni* also repeatedly adduct the pectoral fins to advance the body during climbing (Blob et al. 2007), climbing juveniles rely on axial motion and make little use of the pectoral fins, occasionally using them as struts to improve purchase on the substrate or to change direction (Schoenfuss and Blob 2003).

*Sicyopterus stimpsoni* is endemic to the Hawaiian Islands and can be found in most perennial streams of the chain, where it is exposed to a range of flow conditions (Fitzsimons et al. 1993; Fitzsimons and Nishimoto 1995; Schoenfuss et al. 2004). Although many Hawaiian streams contain waterfalls, there are large differences in stream morphology among islands due to their sequential emergence over millions of years (Carson and Clague 1995).

**Table 1** Anatomical variables measured in juvenile and adult fishes and predicted significance of the variable to predict climbing success

	Anatomical variable	Predicted significance for climbing performance		Measured in juveniles	Measured in adults
1	Head height	Tall head may increase drag	–	Yes	Yes
2	Pectoral fin base length	Neutral	0	Yes	Yes
3	Midbody height	Tall body may increase drag	–	Yes	Yes
4	Caudal peduncle height	Tall body may increase drag	–	Yes	Yes
5	First dorsal fin base length	Neutral	0	Yes	No
6	Second dorsal fin base length	Neutral	0	Yes	Yes
7	Anal fin base length	Neutral	0	Yes	Yes
8	Head length	Elongation may reduce drag	+	Yes	Yes
9	Trunk length	Elongation may reduce drag	+	Yes	Yes
10	Head width	Broad head may increase drag	–	Yes	Yes
11	Trunk width	Broad body may increase drag	–	Yes	Yes
12	Anal width	Broad body may increase drag	–	Yes	No
13	Pectoral fin margin length	Neutral	0	Yes	Yes
14	Sucker width	Larger sucker may increase adhesion	+	Yes	No
15	Sucker length	Larger sucker may increase adhesion	+	Yes	Yes
16	Mass	Could indicate better body condition, or require greater effort to transport	?	Yes	No

+, increased success rate; –, reduced success rate; 0, no effect on climbing success; ?, potential for either increased success or failure. Numbers in the first column correspond to measurements labeled in Fig. 4. Pectoral fin variables were chosen to reflect their occasional use as a stabilizing strut by climbing juveniles, rather than their possible use during climbing or swimming by adults.

Waterfalls are frequently close to shore on the youngest island, Hawai'i, whereas many waterfalls have receded far inland due to erosion on the oldest major island, Kaua'i. Thus, juvenile *S. stimpsoni* on Hawai'i face the challenge of waterfalls with extreme flow conditions very soon upon entering streams, while juveniles on Kaua'i encounter long, meandering streams for great distances during their migration (Fig. 1). This reduces challenges for Kaua'i fish in response to flow, but they encounter a different challenge as a result, because the native predator *E. sandwicensis* is abundant in the slower flowing, lower reaches of streams (Fig. 1; Fitzsimons et al. 1997; Schoenfuss and Blob 2007).

The divergent habitats of Hawai'i and Kaua'i thus present juvenile *S. stimpsoni* with different primary selective pressures in which different morphological phenotypes may be advantageous. The physical demands of climbing rock surfaces through fast-flowing water might convey advantages to body shapes that minimize drag and improve adhesive capacity (Table 1). Successful climbers, therefore, would be expected to possess heads (and potentially bodies) that are narrower and lower in height than unsuccessful climbers, reducing the frontal area exposed to flow and decreasing turbulence (Hoerner 1958; Webb 1989; Vogel 1994; Domenici 2003). Successful climbers might exhibit values of

morphological indices (e.g., fineness ratio, lengthening and flattening indices) closer to optimal values for drag reduction than would unsuccessful climbers (Arnold and Weihs 1978; Webb 1989; Blake 2006). Anatomical variables that may improve adhesion during climbing (e.g., width and length of suckers, marginal length of the pectoral fins) also would be expected to be larger in successful climbers (Maie et al. 2007). Such morphological features of successful climbers might be accentuated among *S. stimpsoni* from Hawai'i, while *S. stimpsoni* from Kaua'i might show deeper bodies that could improve escape performance (Walker 1997; Domenici et al. 2008). Other anatomical variables that might improve escape performance (e.g., larger median fins) might have little impact on climbing success.

In this study, we combined laboratory selection experiments on juvenile *S. stimpsoni* and morphometric analyses of field-collected adults. These studies addressed the questions of whether (1) subpopulations of fish exposed to brief periods of intense flow experience selection for morphological features advantageous for resisting flow, and whether (2) these aspects of body shape are retained in populations of adults not subjected to recurring exposure to extreme flows. To examine these questions, we recorded body shapes of juveniles that successfully climbed artificial waterfalls and compared them with those of

individuals that failed. We also measured the body shapes of adult *S. stimpsoni* from Hawai'i and Kaua'i to evaluate whether these differed, and whether differences could be predicted from the results of selection experiments on waterfall-climbing juveniles. By measuring selection induced by extreme flow on the morphological characters of juveniles, and evaluating the correspondence of these results with differences between adult subpopulations that experienced different flow regimes as juveniles, these studies provide an unique opportunity to evaluate the impact of exposures to brief, intense flow on the morphology of fishes and the potential of such flows to promote phenotypic variation among populations (Fuller et al. 2005).

## Materials and methods

### Selection experiments with waterfall-climbing juveniles

Juvenile *S. stimpsoni* were collected with dip nets from the lower reaches of Hakalau stream on the Island of Hawai'i (Fig. 2) (same location as used by Schoenfuss and Blob 2003, Blob et al. 2006). Collections were made downstream from the top of a 1 m vertical concrete embankment. These animals were all fresh recruits into the stream; judged by their transparency, they had been in fresh water <48 h at the time of their capture (Schoenfuss and Blob 2003; Blob et al. 2006). Within 2 h of capture, animals were transferred in stream water to facilities provided by the Department of Land and Natural Resources, Division of Aquatic Resources in Hilo, Hawai'i. Groups of fish were acclimated overnight in

aerated stream water at 19°C (within 1°C of original stream temperature) (Schoenfuss et al. 2004).

Two sets of selection experiments, based on procedures similar to those in our previous studies of climbing by gobies (Fig. 3; Blob et al. 2006, 2007), were performed to correlate climbing success or failure with variation in body shape. In our first experiment, pairs of juveniles were challenged with a 150 cm climbing chute. Briefly, two fishes were introduced into a 60 × 45 × 15 cm basin half filled with stream water and containing a rock to provide cover. The climbing chute was constructed from a section of plastic rain gutter and was extended from the basin at >80° from horizontal. The climbing surface was coated with fine-grained sand attached to the gutter with spray glue. Stream water was washed over the chute to remove chemical residue. To generate flow over the climbing surface, a siphon was used to direct acclimated stream water from a 20 l bucket down the chute at a flow rate of ~200 ml/min and a depth of 1–1.5 mm. If climbing did not commence within 20 min of the introduction of the fish, they were removed and a new pair of fish was introduced. Our second experiment attempted to better replicate natural climbing conditions by testing larger groups of individuals simultaneously, reflecting the tendency of this species to climb *en masse* (Nishimoto and Fitzsimons 1999). Groups of approximately 20 juveniles were challenged with a 240 cm climbing chute. Procedures for these trials closely followed those for the 150 cm experiments, except that the chute was angled at ~70° to improve its stability.

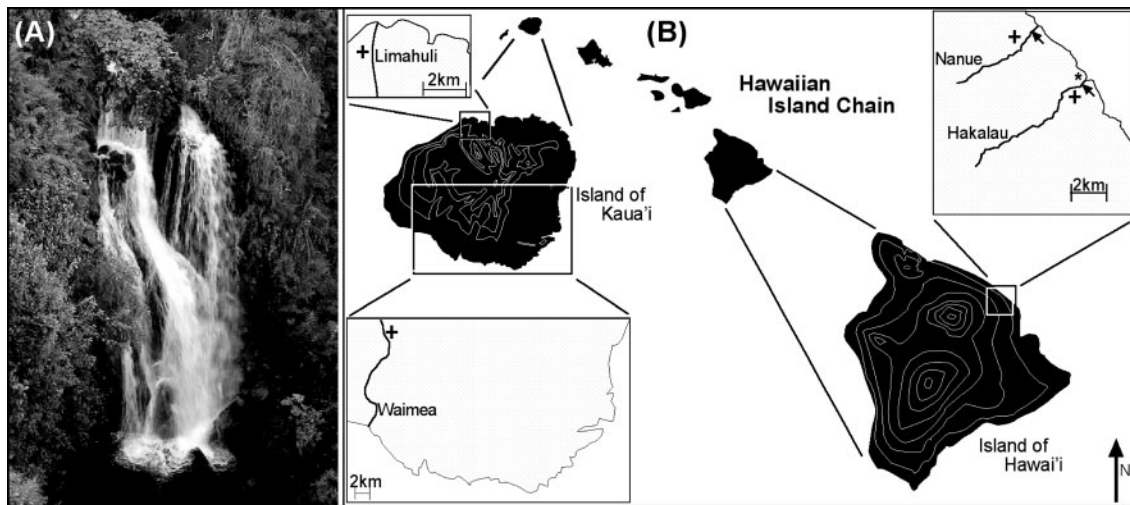

Fig. 2 (A) Waterfall of Umauma Stream, Hamakua Coast, Island of Hawai'i. Falls such as these are typical of the high-velocity flows scaled by juvenile *S. stimpsoni* during migrations to habitats used by adults. (B) Sampling locations for juvenile (\*, Hakalau Stream only) and adult (+) *S. stimpsoni*. Arrows indicate locations of prominent waterfalls.

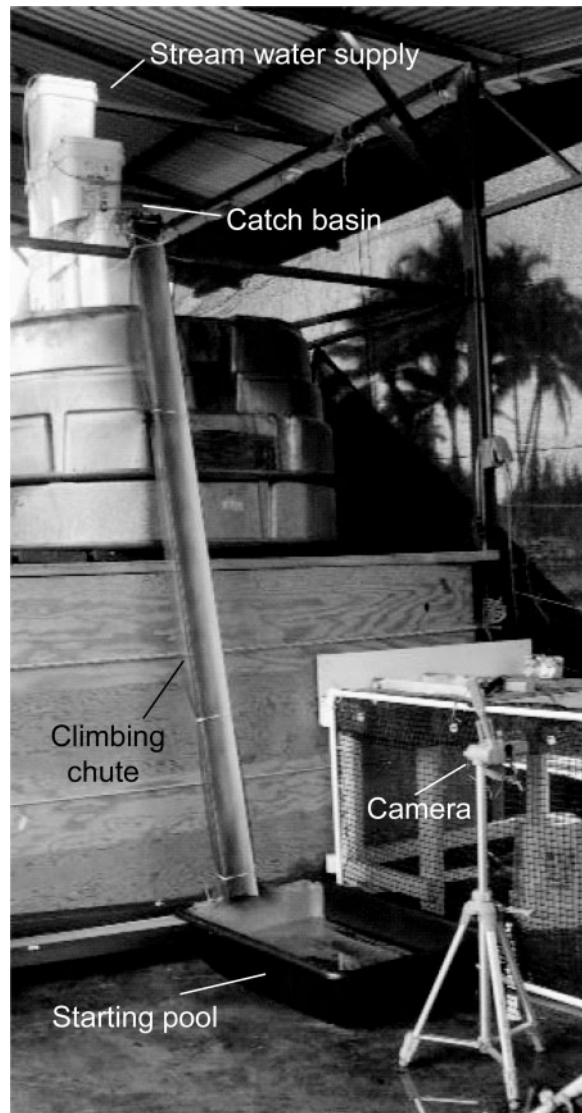

Fig. 3 Illustration of experimental arena used for selection experiments on climbing in juvenile *S. stimpsoni*.

Climbing performance in both sets of experiments was evaluated as either success, for fish reaching the top of a chute, or failure, for fish that failed to climb or that attempted climbing but failed to reach the top. We considered this grouping of “successful” and “failed” as most ecologically relevant because only fish reaching the top of the waterfall will have overcome this crucial phase in their migration to the upstream reaches. Fishes were collected upon completion of trials, sorted into groups of successful and failed climbers, and preserved in 40% ethanol. Each fish was then digitally photographed in lateral and ventral views and weighed to the closest 0.01 g. Linear measurements of anatomical variables were obtained using NIH Image 1.62 (Table 1, Fig. 4). Features were selected for measurement based on

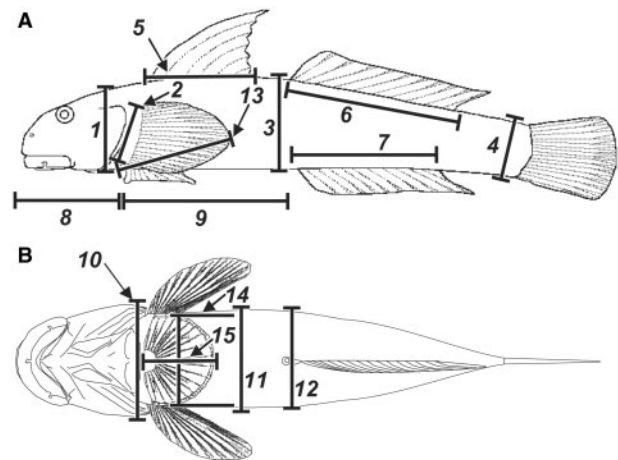

Fig. 4 Anatomical variables measured from specimens of *S. stimpsoni*. See Table 1 for description of each numbered variable. (A) Lateral view. (B) Ventral view.

their expected relevance to climbing performance, or their likely relevance to predator avoidance (the focus of a complementary study in preparation; Table 1).

The strength of directional selection induced on each morphological character by climbing through flowing water was evaluated using procedures outlined by Lande and Arnold (1983) for longitudinal data. To help standardize our sample for differences in body condition among individuals, a body condition index ( $BCI = \text{body length}^3 / \text{body mass}$ ) was calculated for each fish prior to analysis. Trials from fish with  $BCI > \pm 2$  SD from their population mean were excluded. After exclusion of fish with BCI values outside the designated range, our first experiment included data from 157 fish, and our second experiment included data from 224 fish. To further standardize our sample, all variables were corrected for body size using the transformation  $[\ln(\text{variable}) - \ln(\text{total length})]$  prior to analysis (Mosimann and James 1979). Juveniles showed a very limited range of body lengths (mean  $\pm$  SEM =  $22.21 \pm 0.04$  mm), indicating that any potential effects of differences in allometric growth among juveniles on our analysis would be minimized.

The imposition of selective regimes can have direct effects on the distributions of phenotypic traits in a population; such effects are characterized as direct selection (Lande and Arnold 1983). However, selective regimes also can affect distributions of characters indirectly if selection on one character produces responses in other characters that are correlated with the first (e.g., through allometric or genetic associations; Lande and Arnold 1983). Lande and Arnold's (1983) methods evaluate the significance of both

direct and indirect directional selection through comparisons of two parameters: the directional selection differential ( $s$ ) and the directional selection gradient ( $\beta$ ). Selection differentials ( $s$ ) indicate change in a character's mean due to both direct and indirect directional selection, and were calculated for each character as the difference between the character's mean prior to selection and the mean for successful climbers. Successful climbers were assigned an absolute fitness ( $W$ ) of 1 and unsuccessful climbers a  $W$  of 0, with all-or-nothing designations reflecting an assumption that partial ascension of a waterfall represents failure to reach the habitat of reproductive adults. We then transformed  $W$  to relative fitness ( $w$ ) by dividing  $W$  by mean population fitness, standardized each  $s$  value by the SD of the character (producing the parameter  $s'$ ), and tested the significance of  $s'$  values with Spearman rank correlations of relative fitness with the characters. Directional selection gradients ( $\beta$ ) indicate the strength of direct directional selection on each character. Following the modifications of Lande and Arnold's (1983) methods recommended by Janzen and Stern (1998), we calculated a selection gradient vector ( $\beta_{\text{avggrad}}$ ) from logistic multiple regression of relative fitness on all characters. Comparisons of the significance (determined at  $P < 0.10$  to reduce type II error, as well as  $P < 0.05$ ) and sign of  $s'$  and  $\beta_{\text{avggrad}}$  indicate how the selective regime acts on each character. In our initial calculations, a result in which successful climbers had a larger value for a trait than did unsuccessful climbers would have received a counterintuitive negative value of  $s'$ ; therefore, to simplify interpretation of our results, we multiplied all  $s'$  and  $\beta_{\text{avggrad}}$  values by  $(-1)$ , so that a positive sign for these parameters indicated a larger value for a trait in successful climbers. After this conversion, a significant positive  $s'$  and  $\beta_{\text{avggrad}}$  for a character would indicate direct directional selection on that character and a positive correlation between the size of that structure and climbing success. As an example of one possible contrasting scenario, significant negative  $s'$  without significant  $\beta_{\text{avggrad}}$  for a character would indicate that smaller structures were correlated with climbing success, but through indirect directional selection on the character as a result of its correlation with other characters. Logistic regressions and Spearman rank correlations were calculated using SAS (Cary, NC, USA, Version 9.1). The selection gradient vector ( $\beta_{\text{avggrad}}$ ) was calculated twice, once including all measured variables (including those to be used in a complementary study) and a second time using a smaller set of variables, including only those variables assumed a priori to be affected by the

selective pressures of an environment with high-velocity flow. Comparison of these two calculations of selection gradient vectors allowed us to evaluate the impact of omitted variables on the interpretation of selection parameters (Lande and Arnold 1983).

Hydrodynamic performance, including drag reduction, can be correlated with the relative proportions of body dimensions as well as with the values of single linear measurements (Arnold and Weihs 1978; Webb 1989; Blake 2006). Therefore, from our morphological measurements, we also calculated the functional parameters of fineness ratio (length/maximum height), flattening index (maximum width/maximum height), and lengthening index (length from rostrum to location of maximum height/length) to further compare morphological drag reduction between successful and unsuccessful climbers. Because these ratios are based on combinations of the linear morphological variables under study, they cannot be included in multiple regression calculations of selection gradients with the variables from which they are derived. Instead, we calculated selection differentials for these three ratios between successful and unsuccessful climbers, and tested if significant selection favored values of these parameters closer to optimal values for drag reduction in successful climbers (10 for fineness ratio, 2 for flattening ratio, and 0.3 for lengthening ratio) (Blake 2006) using Spearman rank correlations.

### Morphometric analyses of adult specimens

Adult *S. stimpsoni* were collected while snorkeling using an 'opae net (a fine-mesh net with a narrow opening at the top of a bowl-shaped basket). Collections were made from Hakalau and Nanue streams on the Island of Hawai'i and from Limahuli and Waimea streams on the Island of Kaua'i (Fig. 2). Specimens were preserved in either 70% ethanol or 70% isopropyl alcohol, shipped to our home laboratories, and measured within weeks after preservation, thereby limiting the potential for distortion of specimens (Martin 1978; Lee 1982). Body dimensions were measured from 55 adult *S. stimpsoni* using digital calipers (Table 1). The sex of each specimen was determined by abdominal dissection and examination of the gonads after measurements were collected.

To test for morphological differences between island subpopulations of *S. stimpsoni*, we performed a discriminant function analysis (DFA) in Systat (Version 10, Chicago, IL, USA) on our measured anatomical variables to calculate functions that provided the maximum distinction between the

predetermined groups that we sought to compare (Neff and Marcus 1980; Krzanowski 2000). To consider possible sex-related differences in adult body shape that might not have emerged among juveniles, we designated specimens as belonging to one of four groups: Hawai'i females ( $N=9$ ), Hawai'i males ( $N=23$ ), Kaua'i females ( $N=11$ ), or Kaua'i males ( $N=12$ ), with total lengths (mean  $\pm$  SEM) of  $81.8 \pm 3.6$ ,  $76.9 \pm 5.6$ ,  $74.5 \pm 4.2$  and  $92.2 \pm 6.9$  mm, respectively. Analysis of variance (ANOVA) indicated no significant difference in length among these groups ( $F_{(3,51)}=2.10$ ,  $P=0.11$ ), thereby minimizing the possibility of allometric scaling differences between sexes or islands affecting our comparisons. However, to account for variation in body size among individuals, all variables were standardized for body size prior to analysis using the transformation [ $\ln(\text{variable}) - \ln(\text{total length})$ ] (Mosimann and James 1979). After DFA, we evaluated  $F$ -statistics calculated between our groups to determine if their separation was significant (Engelman 1996). To test which morphological characters led to group separation, we tested the significance of correlations between the original variables and the new DFs (Rohlf and Sokal 1995, Table R).

## Results

### Selection experiments on juvenile fish

In both waterfall-climbing experiments, fish climbed readily with 70% of fish in the shorter, paired-climbing experiment successful, and 71% of fish in the taller, group-climbing experiment successful. The readiness of juvenile *S. stimpsoni* to climb matched our observations from previous studies (Schoenfuss and Blob 2003; Blob et al. 2006, 2007). Moreover, the similar success rates in both experiments suggest that the use of group-climbing trials did not introduce substantial confounding factors that altered the climbing performance of individuals. Our observations indicated that fish failing to climb to the top of the waterfall were usually at the tail end of groups, frequently adhering to the surface of the climbing chute at a low height until the end of the experiment. Thus, failing fish did not impede the progress or success of other fish in a group. Proportions of successful climbers were generally similar across all of our trials, allowing us to pool our samples for each of the two climbing distances in order to obtain adequate sample sizes for multiple regression analyses of selection gradients (Lande and Arnold 1983).

Successful and unsuccessful climbers did not differ significantly in body length in either experiment

(ANOVA,  $P=0.11$  and  $P=0.71$ , respectively), but significant differences in body shape were found between successful and unsuccessful climbers in both experiments. However, the anatomical variables that showed significant differences differed between these two experiments. In the first experiment, significant selection differentials were found for six linear variables (Table 2). Two of these differentials (greater head length and narrower head width among successful climbers) met expectations for variables that would be advantageous in reducing drag (Webb 1989; Vogel 1994). One variable (sucker width) contradicted our expectations and was found to be smaller in successful climbers, even though a larger suction disc should aid in adhesion (Maie et al. 2007). The remaining three variables (lengths of the bases of the first dorsal fin, second dorsal fin, and anal fin) were all shorter in successful climbers compared to unsuccessful climbers. These variables had not been predicted to show differences between successful and unsuccessful climbers. Among the three ratio variables, fineness ratios (ranging from 8.2 to 8.4) were particularly close to the optimal, minimum drag value of 10 (Blake 2006), but only lengthening ratio showed a marginally significant ( $P=0.094$ ) selection differential (Table 3). Although the mean lengthening ratio of successful climbers was smaller than the character mean prior to selection (opposite of expectations for optimal reduction of drag), the numeric difference between the groups was very small (0.001). Fineness ratio and flattening ratio were both closer to optimal values among successful climbers, but their selection differentials were not significant (Table 3).

Selection gradients in the first experiment showed differing patterns of significance depending on whether our analysis included variables expected to be neutral in contributing to climbing success. For the complete data set, only the length of the first dorsal fin base and anal fin base showed significant gradients, both of which were shorter in successful climbers, indicating direct directional selection on these traits. These two variables were not included in our climbing-specific data set because neither was predicted to have a significant impact on climbing success. In our analysis of the restricted set of variables, successful climbers showed significant selection gradients indicating direct selection for longer and narrower heads (Table 2). Comparing selection differentials with each of these sets of selection gradients, waterfall climbing appears to induce direct directional selection shortening the lengths of the first dorsal and anal fins, while indirect directional

**Table 2** Selection differentials and gradients for linear anatomical variables of juvenile *S. stimpsoni* assessed in experiments involving the climbing of waterfalls

Anatomical variable	Paired 150 cm climbing trial (N = 110 successful, 47 failed)			Group 240 cm climbing trial (N = 159 successful, 65 failed)		
	s'	$\beta_{\text{avggrad}} \pm \text{SE}$		s'	$\beta_{\text{avggrad}} \pm \text{SE}$	
		All	Expected		All	Expected
Head height	-0.070	-0.030 ± 0.037	-0.014 ± 0.037	-0.299**	-0.102 ± 0.026**	-0.130 ± 0.029**
Pectoral fin base length	-0.028	0.004 ± 0.040	N/A	-0.129**	-0.054 ± 0.022**	N/A
Midbody height	0.048	0.086 ± 0.062	0.077 ± 0.061	0.204**	0.047 ± 0.040	0.079 ± 0.044*
Caudal peduncle height	-0.041	0.020 ± 0.044	-0.029 ± 0.039	0.041	0.011 ± 0.028	-0.047 ± 0.030
First dorsal fin base length	-0.151**	-0.071 ± 0.041*	N/A	-0.060	0.011 ± 0.021	N/A
Second dorsal fin base length	-0.156**	-0.056 ± 0.046	N/A	-0.103**	-0.027 ± 0.027	N/A
Anal-fin base length	-0.189**	-0.085 ± 0.050*	N/A	-0.192**	-0.111 ± 0.029**	N/A
Head length	0.095*	0.024 ± 0.042	0.069 ± 0.042*	0.000	-0.005 ± 0.026	0.014 ± 0.028
Trunk length	0.021	0.022 ± 0.039	0.036 ± 0.042	0.036	-0.014 ± 0.025	0.031 ± 0.026
Head width	-0.118**	-0.050 ± 0.047	-0.093 ± 0.046**	-0.037	-0.027 ± 0.025	-0.035 ± 0.025
Trunk width	0.000	0.044 ± 0.070	0.049 ± 0.069	0.106**	-0.110 ± 0.048**	-0.102 ± 0.050**
Anal width	-0.013	-0.065 ± 0.068	-0.028 ± 0.064	0.205**	0.171 ± 0.058**	0.166 ± 0.057**
Pectoral fin margin length	-0.039	0.031 ± 0.040	-0.011 ± 0.039	0.199**	0.088 ± 0.025**	0.081 ± 0.026**
Sucker width	-0.117*	-0.010 ± 0.040	-0.036 ± 0.041	-0.105*	-0.055 ± 0.024**	-0.058 ± 0.026**
Sucker length	-0.047	-0.063 ± 0.043	-0.053 ± 0.044	0.014	0.057 ± 0.025**	0.038 ± 0.027
Mass	0.042	0.025 ± 0.063	N/A	0.113**	0.017 ± 0.032	N/A

s', standardized directional selection differential (s/character SD);  $\beta_{\text{avggrad}}$ , standardized directional selection gradient derived from logistic regression; all, data set including all anatomical measurements; expected, data set including only measurements expected to affect climbing success in flow.

\* $P < 0.10$ ; \*\* $P < 0.05$ .

selection may also contribute to increased streamlining of the head and decreased width of the sucker.

In the second experiment, a greater number of linear variables (10) showed significant selection differentials. Two variables showed expected patterns of difference between successful and unsuccessful climbers, with head height smaller and the length of the margin of the pectoral fin greater in successful climbers (Table 2). However, midbody height, trunk width, and anal width were all greater in successful climbers, contrary to our expectations. Also contrary to our expectations, sucker width was smaller in successful climbers. The remaining four linear variables showing significant selection differentials (lengths of the pectoral fin, second dorsal fin, and anal fin bases, as well as mass), had not been predicted to show differences between successful and unsuccessful climbers, but the three fin measurements were all smaller in successful fish, whereas mass was greater in successful fish. Among the three ratio variables, only fineness ratio showed a significant selection differential, and this indicated that successful climbers had values closer to the optimum for minimal drag (Table 3).

Selection gradients in the second experiment showed similar patterns of significance between our analyses that included variables expected to be neutral in contributing to climbing success versus those that excluded such variables (Table 2). Five variables (head height, trunk width, anal width, length of the margin of the pectoral fin, and sucker width) showed similar differences in body shape between successful and unsuccessful climbers in both data sets. However, two characters that were excluded from the variable-restricted analysis (lengths of the base of the pectoral and anal fins) were both smaller in successful climbers. Two variables showed significant differences in one, but not the other, analysis. Midbody height was not significantly different in the analysis of the complete data set, but was significantly larger in the variable-restricted analysis. In contrast, sucker length was significantly greater in the analysis of the complete data set, but did not vary significantly in the variable-restricted analysis.

Comparing selection differentials with each of these sets of selection gradients for our second experiment, climbing of waterfalls appears to induce

**Table 3** Selection differentials for ratio variables (hydrodynamic indices) of juvenile *S. stimpsoni* assessed in experiments involving the climbing of waterfalls

	Paired 150 cm climbing trial (N = 110 successful, 47 failed)			Group 240 cm climbing trial (N = 159 successful, 65 failed)		
	Fineness ratio	Flattening index	Lengthening index	Fineness ratio	Flattening index	Lengthening index
Optimal value for low drag (Blake 2006)	10	2	0.3	10	2	0.3
Trait mean $\pm$ SD (all fish)	8.290 $\pm$ 0.512	0.898 $\pm$ 0.043	0.206 $\pm$ 0.009	8.272 $\pm$ 0.453	0.917 $\pm$ 0.045	0.205 $\pm$ 0.009
Trait mean $\pm$ SD (successful climbers)	8.316 $\pm$ 0.545	0.900 $\pm$ 0.044	0.205 $\pm$ 0.008	8.356 $\pm$ 0.451	0.919 $\pm$ 0.044	0.205 $\pm$ 0.008
$s'$	0.051	0.047	-0.111*	0.185**	0.044	0
$P$	0.261	0.398	0.094	<0.001	0.143	0.846

$s'$  = standardized directional selection differential ( $s$ /character SD).

\* $P$  < 0.10; \*\* $P$  < 0.05.

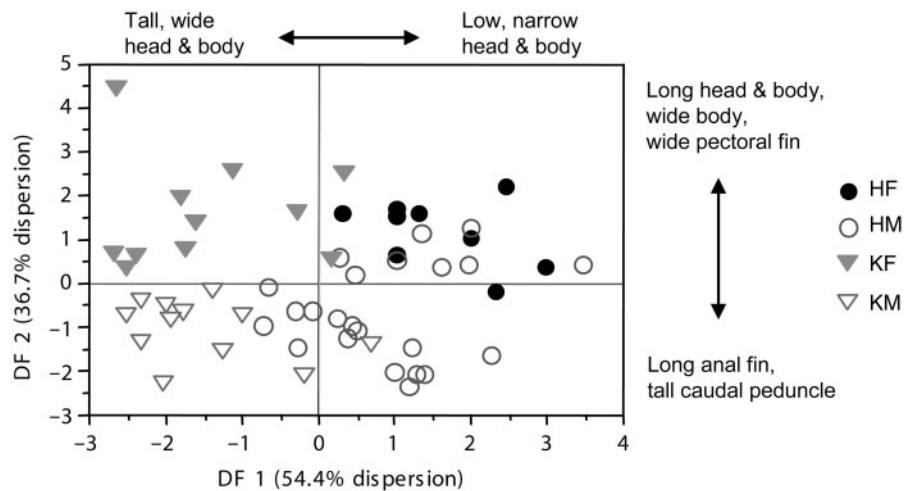

**Fig. 5** DF1 versus DF2 for 55 *S. stimpsoni*: HF, Hawai'i female; HM, Hawai'i male; KF, Kaua'i female; KM, Kaua'i male. Regardless of sex, fish from Kaua'i and Hawai'i differ significantly on DF1.

direct directional selection on six anatomical variables. Head height, length of the base of the pectoral and anal fins, and sucker width were all smaller in successful climbers, whereas anal width and length of the margin of the pectoral fin were both greater. In addition, trunk width showed direct directional selection to be significantly smaller in successful climbers, but selection differentials indicated it was significantly larger in successful climbers. This result suggests that direct selection for narrower trunks was masked by the additional action of indirect directional selection on this variable through some correlated character(s). Furthermore, sucker length showed no significant selection differential, but showed a significant increase through its directional selection gradient, indicating indirect selection may be masking direct selection on this variable as well. Finally, selection differentials indicated that successful climbers had a larger length-normalized body mass than did unsuccessful climbers, but the

selection gradient for mass was not significant, indicating that difference in mass is the result of indirect directional selection on this variable.

### Morphometric comparisons among adults

DFA showed significant inter-island differences in functionally relevant morphology for adult *S. stimpsoni* (Fig. 5, Tables 4 and 5). Compared to the critical value for our sample ( $F_{0.05(14, 38)} = 2.362$ ), there is significant (and substantial) separation in morphology between all groups from Hawai'i versus all groups from Kaua'i (Table 4). In contrast, there is no significant morphological separation between female and male *S. stimpsoni* from Hawai'i, and only a marginally significant separation between females and males from Kaua'i. The first two factors of the DFA accounted for 91.1% of the dispersion of the sample (DF1 = 54.4%, DF2 = 36.7%), with separation between islands occurring along DF1 and separation between sexes occurring along

**Table 4** Between-group *F*-matrix for discriminant function analysis of morphological measurements from males and females of the climbing goby *S. stimpsoni* from the islands of Hawai'i and Kaua'i

	HF	HM	KF	KM
HF	0.000			
HM	1.790	0.000		
KF	2.898 <sup>a</sup>	3.977 <sup>a</sup>	0.000	
KM	4.073 <sup>a</sup>	2.829 <sup>a</sup>	2.395 <sup>a</sup>	0.000

<sup>a</sup>Values greater than critical value of  $F_{0.05(14, 38)} = 2.362$ . HF, Hawai'i females; HM, Hawai'i males; KF, Kaua'i females; KM, Kaua'i males.

**Table 5** Correlations of measured anatomical variables (Table 1) with discriminant function axes calculated to distinguish four groups of adult *S. stimpsoni* illustrated in Fig. 5 (females from Hawai'i, males from Hawai'i, females from Kaua'i, males from Kaua'i)

	Anatomical variable	DF 1	DF 2
1	Head height	-0.578*	0.100
2	Pectoral fin base length	-0.436*	0.515*
3	Midbody height	-0.360*	0.224
4	Caudal peduncle height	-0.271*	-0.501*
6	Second dorsal fin base length	0.075	-0.150
7	Anal fin base length	-0.244	-0.876*
8	Head length	-0.164	0.404*
9	Trunk length	-0.064	0.715*
10	Head width	-0.653*	0.274*
11	Trunk width	-0.782*	0.327*
13	Pectoral fin margin length	-0.398*	-0.141
15	Sucker length	-0.583*	0.106

Numbers in first column correspond to measurements labeled in Fig. 4; note that not all variables measured for juveniles were measured for adults (Table 1). \*For  $df = 53$ , correlations  $>0.266$  are significant at  $P < 0.05$  (Rohlf and Sokal 1995).

DF2 (Fig. 5). On DF1, *S. stimpsoni* from Hawai'i have lower and narrower heads and bodies than do *S. stimpsoni* from Kaua'i (Fig. 5, Table 5). *Sicyopterus stimpsoni* from Hawai'i also have longer suckers and longer and wider pectoral fins than do *S. stimpsoni* from Kaua'i. The low, narrow heads and bodies of adult *S. stimpsoni* from Hawai'i should reduce drag in flowing water, features that would have been advantageous for juvenile fish that climbed waterfalls with high-velocity flows. *Sicyopterus stimpsoni* from Kaua'i, however, have larger pectoral fins and longer suckers (Table 5). Separation along DF2 showed that females tended to have longer heads and bodies than did males, but also wider bodies and wider pectoral fins; in contrast, males had longer anal fins and taller caudal peduncles (Fig. 5, Table 5). This separation, however, appears to have been driven primarily by differences between males and females from Kaua'i,

as males and females from Hawai'i largely overlapped on DF2 (Fig. 5) and, as noted above, did not show significant separation (Table 4).

The smaller height and width of the head observed in adult *S. stimpsoni* from the Island of Hawai'i compared to adult fish from Kaua'i matches well with results of selection experiments on climbing juveniles. Significant direct directional selection favoring flatter heads was found in the second selection experiment, and a significant selection differential for narrower heads in successful climbers was found in the first selection experiment. However, other morphological differences between adult populations did not correspond with the morphological differences found between successful and unsuccessful juvenile climbers. For example, adult *S. stimpsoni* from Hawai'i had a narrower body that was not as tall as that of fish from Kaua'i (Fig. 5). However, successful juvenile climbers showed wider and taller bodies than did unsuccessful climbers (Table 2), in contrast to expectations based on hydrodynamic principles.

## Discussion

### Flow-induced selection on morphological features of waterfall-climbing fishes

Our experiments indicate that the extreme flow environments of waterfalls have the capacity to induce substantial directional selection on a wide range of morphological features in climbing gobies. However, the effects of selection on morphology were more complicated than anticipated, and did not always match our predictions based on hydrodynamic principles. Several differences in shape between successful and unsuccessful climbers did appear to reflect the reduction of drag and, potentially, an increase in adhesive capacity. For example, both of our selection experiments showed evidence for direct directional selection with successful climbers having head shapes that would reduce drag. Successful climbers had significantly longer and narrower heads than unsuccessful climbers in our first (shorter chute) experiment, and had significantly lower-profile heads in our second (group-climbing) experiment (Table 2). In addition, both experiments showed trends for successful climbers to have fineness ratios closer to the optimal value for drag reduction than unsuccessful climbers, although this selection differential was highly significant only in the group-climbing experiment. Other features that had not been predicted to significantly influence climbing success also exhibited direct directional selection, but can still be interpreted as facilitating

drag reduction. Across both selection experiments, the bases of the second dorsal fin and anal fin were shorter in successful climbers, and the first dorsal fin was also significantly shorter in successful climbers in our first, shorter climbing experiment (Table 2). The shapes of these fins had not been expected to significantly influence climbing success because these fins are typically folded against the body during climbing (Schoenfuss and Blob 2003). However, reduction in the size of these fins might reduce drag more than we anticipated. Reduction of the anal fin also could allow better contact of the ventral surface of the tail with the climbing substrate. Although the tail does not appear to actively contribute to propulsion during climbing in *S. stimpsoni* (Schoenfuss and Blob 2003), closer contact of the tail with the substrate might reduce slippage, thereby making dislodgement less likely.

Improved adhesion might also be reflected in selection patterns observed for the length of the pectoral fin. The margin of the pectoral fin was significantly longer in successful climbers from our second, group-climbing experiment, potentially improving purchase on the substrate or the ability to adjust climbing direction during ascent of a waterfall (Schoenfuss and Blob 2003). This response differs from what might be expected in the context of data from typical non-climbing fishes exposed to high flow, in which the pectoral fins are usually shorter in individuals living in high-flow conditions (Peres-Neto and Magnan 2004), potentially helping to reduce drag (Drucker and Lauder 2003).

Some of the differences in shape between successful and unsuccessful climbers were counterintuitive. Midbody height, trunk width, and anal width all indicated direct directional selection to be larger in successful climbers in the group-climbing experiment. These differences in body shape might be expected to increase drag and, thereby, decrease the likelihood of successful climbing. It is possible that these features do not affect drag as severely as expected; alternatively, the patterns we observed may reflect other, undetermined features of the fish that counterbalance adverse effects of the increased drag they convey (Møller 1996; DeWitt et al. 1998). For example, the greater girth of the body of successful climbers could indicate elevated mass of propulsive muscles or superior body condition compared to unsuccessful climbers. In fact, in one of our selection experiments successful climbers did exhibit higher body mass as a result of indirect selection. Deep-bodied juveniles might also have lower standard metabolic rates than shallow-profile individuals, helping to decrease their cost of transport despite

elevated hydrodynamic drag (Pettersson and Brönmark 1999; Pettersson and Hedenström 2000). These possibilities require further exploration.

Also unexpected were the patterns of selection on sucker dimensions in both experiments. In the longer, group-climbing experiment, there was significant direct selection for longer suckers in successful climbers but not a significant selection differential between successful and unsuccessful climbers for this trait, indicating that indirect selection on correlated characters was masking this effect. In addition, there was direct directional selection leading to decreased sucker width. Although larger overall sucker areas should increase adhesive capacity (Emerson and Diehl 1980; Kier and Smith 1990, 2002; Maie et al. 2007), the distribution of this area might be more advantageous if it presented a smaller frontal area subject to dislodgement by forces of flowing water (Vogel 1994). It is puzzling that smaller sucker widths emerged as significant in successful climbers, but that complementary greater sucker lengths did not, suggesting that sucker areas were relatively smaller in successful climbers. Developmental or allometric constraints on sucker proportions (Maie et al. 2007) might play a role in this pattern, if narrower suckers required shorter lengths as well. Also puzzling were the patterns of selection on sucker dimensions that emerged from our shorter climbing experiments, in which there was a significant selection differential indicating smaller sucker width in successful climbers (Table 2). However, the selection gradient was not significant for this variable, indicating no direct directional selection on this trait. This suggests that the difference in dimensions of suckers between successful and unsuccessful climbers resulted from indirect selection through correlated characters.

Although there were noteworthy differences in results between our two selection experiments, several morphological variables showed consistent patterns. Different aspects of head shape were found to differ significantly between successful and unsuccessful climbers in the two experiments, but in both experiments successful climbers had head shapes that would be expected to help reduce drag. Moreover, in both experiments, dorsal and anal fins exhibited direct directional selection with shorter fins among successful climbers that could decrease drag and improve attachment to the surface. However, more significant differences emerged in the longer, group-climbing experiment than in the shorter, paired-climbing experiment (Table 2). These differences may reflect the more rigorous selection pressure of the taller waterfall, and the more realistic group-climbing design.

### Correspondence between selection–experiment patterns and adult subpopulation differences

The differences in shape between adult *S. stimpsoni* from Hawai'i and Kaua'i suggest the possibility that the differing flow regimes encountered on these islands may impose selection that leads to morphological divergence in this species. In some cases, the differences in body shape evident after our selection experiments corresponded well with the differences in the shapes of adults from high-flow environments on Hawai'i and lower flow environments on Kaua'i. For example, in selection experiments, successful climbers had heads better suited for drag reduction than did unsuccessful climbers, and lower, narrower heads were also found in adult *S. stimpsoni* from Hawai'i versus adult *S. stimpsoni* from Kaua'i (Fig. 5). However, while lower height and narrower bodies were also evident in adult *S. stimpsoni* from Hawai'i versus Kaua'i, this difference in shape was not found between successful and unsuccessful juvenile climbers in our selection experiments. In fact, successful juvenile climbers had wider (although not significantly flatter) bodies than did unsuccessful climbers, a difference in shape that was unexpected based on hydrodynamic principles.

It is striking that the correspondence in results between juvenile selection experiments and comparisons of adult body shapes from populations exposed to different flow regimes is most prominent for variables describing shape of the head, rather than postcranial body shape. In both experiments and in our field-collected adults, head shapes suited for reducing drag were associated with exposure to high-flow regimes. Thus, a high premium is placed on streamlining of the head throughout the ontogeny of this species, while this may be less dramatic for postcranial body regions.

Several factors might contribute to instances in which the results of selection experiments on juveniles do not correspond to the morphological differences between adults from Hawai'i and Kaua'i. First, selection regimes may change between juvenile and adult stages (Ebenman 1992; King 1993; Niskanen and Mappes 2005). Once a juvenile climbs a waterfall, selection for traits that improve climbing success would be relaxed (Blob et al. 2007), but it would not yet have grown to adult proportions (Maie et al. 2007). Continued growth under relaxed (or even differing) selection pressures could contribute to adult *S. stimpsoni* differing in body shape from juveniles, making exposure to differing juvenile selective regimes an incomplete predictor of differences in the morphology of adults between goby

subpopulations. Selection also might operate on morphology in *S. stimpsoni* by favoring phenotypic plasticity, but a plastic response triggered in juveniles might reverse if the stimulus is not maintained throughout growth (Brönmark and Miner 1992; Relyea 2003; Gabriel et al. 2005; Buckley et al. 2007). However, neither of these considerations seem likely to account for cases in which juvenile selection experiments did not favor a drag-reducing feature that was found to be accentuated in adult subpopulations from Hawai'i versus those from Kaua'i, such as lower and narrower bodies (Fig. 5). It is possible that closer correspondence between selection–experiment results and comparisons of adult subpopulations might emerge from selection studies conducted over longer climbing distances, where drag reduction might be of greater consequence.

Our selection experiments apply a well-defined and environmentally relevant selective pressure at a temporally relevant point of juvenile development. In addition, unlike many laboratory selection experiments (Fuller et al. 2005), in our study the selective pressure is initiated by voluntary behavior of the subject individuals (i.e., when the fish commence climbing) rather than by an arbitrary decision of a scientist (i.e., alteration of an environmental variable). Although our experiments addressed only phenotypic selection and cannot account for the evolutionary response of selection across generations, they do indicate the significance of extreme flow as a selective agent during the critical time of juvenile migration of *S. stimpsoni*. Furthermore, for several hydrodynamically important features (e.g., head shape), the congruence of phenotypic selection patterns observed in our experiments with morphological character divergence documented among adult fish from Hawai'i and Kaua'i corroborates our hypothesis that differences in adult morphology may result, at least in part, from the selective pressures of high-velocity flows encountered by migrating juveniles.

### Effects of unmeasured variables on the interpretation of the action of selection

It is noteworthy that, in our selection experiments, analyses of data sets with a smaller set of variables (restricted to variables expected *a priori* to be subject to selective pressures) lead to a different interpretation of which variables experience direct directional selection, as compared to analyses of our data sets that included all of our measured variables. In analyses of our complete data sets, direct directional selection was detected on several fin measurements

that would not have been included in our analyses had our focus only been on variables predicted to affect climbing performance. The importance of unmeasured variables for evaluating the factors that contribute to functional performance have been cited as a concern (Lande and Arnold 1983), but empirical evidence of such omissions affecting interpretations of the action of selection is rarely available. The present study highlights the benefits of broad variable sampling in selection studies and provides a cautionary note for studies attempting to evaluate selection on factors affecting functional performance. In addition, logistic multiple regression analyses including quadratic and interaction terms could provide additional insights into the action of stabilizing and correlational selection, although larger sample sizes would facilitate such analyses (Lande and Arnold 1983; Brodie 1992).

### Suggestions for future studies

Our examinations raise several questions about the significance of flow as a selective pressure on stream goby morphology that require further experimental investigation. For example, what factors contribute to the lower and narrower bodies of adult *S. stimpsoni* from Hawai'i versus Kaua'i, particularly since these differences in body shape do not appear to result from selection for climbing performance? One possibility is that additional selective pressures act on fish living on Kaua'i, potentially making deeper or wider bodies advantageous on this island. For example, the taller bodies of *S. stimpsoni* on Kaua'i might improve their ability to generate thrust and evade predators (Walker 1997; Domenici 2003; Domenici et al. 2008), an advantage on Kaua'i where predator evasion is at a premium. Experiments using successful or unsuccessful evasion of predation as an endpoint could assess the possible action of this type of selection on these aspects of body shape (Swain 1992).

Our selection experiment using taller waterfalls resulted in more variables demonstrating significant selection than did the experiment using shorter waterfalls. Might greater waterfall heights induce more severe selection? Even though the 30% failure rate from both of our selection experiments indicate that we induced substantial selective pressure on juvenile climbers, the corresponding 70% success rate is likely much higher than that occurring in nature. Based on studies of recruitment of incoming juveniles (Nishimoto and Kuamo'o 1997), over 40,000 individual *S. stimpsoni* may migrate annually into Hakalau Stream on the Island of Hawai'i.

Although accurate population estimates are difficult to establish in such an environment, several decades of observations indicate that adult populations are likely an order of magnitude smaller than annual juvenile recruitment. Considering that Hawaiian freshwater gobies live multiple years (Nishimoto and Fitzsimons 1986), even a conservative estimate of a 2-year life span would suggest failure rates of over 90% for incoming juveniles. Selection experiments making use of greater climbing heights could, therefore, provide further insight into the morphological features contributing to the successful navigation of barriers posed by extreme flows.

Another factor potentially contributing to the high failure rate of incoming juvenile gobies relates to their amphidromous life cycle and the oceanic mixing of larvae from different source streams (and islands) that may result (Fitzsimons et al. 1990; Zink et al. 1996; Chubb et al. 1998; McDowall 2001, 2003). Larvae spawned on Kaua'i, for example, may return to freshwater on Hawai'i and encounter waterfall barriers to which their ancestors were not exposed. If differences in shape are the result of additive genetic variance and are inherited from adults that were successful in reaching the spawning habitat, then larvae from an island without pressures like waterfalls might be selected against if they return to an island where such pressures are prominent, increasing the proportion of juvenile failure. Further studies examining local recruitment rates and the level of genetic differentiation between island subpopulations are needed to test whether local recruits have a selective advantage over nonnatal juveniles in overcoming extreme flows.

Many tropical and subtropical volcanic islands contain species of gobioid fishes that climb waterfalls. Do other species of climbing goby exhibit similar patterns of selection on morphological variables when subjected to the extreme flow of waterfalls? Comparative studies of the effects of similar selective pressures on a range of species are uncommon (Reznick and Ghalambor 2005; Irschick et al. 2007). Studies of morphological characters in climbing species of fish on islands in the Caribbean or Indian Ocean (Keith 2003; McDowall 2004; Maie et al. 2007) may shed light on common morphological constraints among fishes exposed to these extreme flow environments.

### Acknowledgments

We thank Mike Fitzsimons, on the occasion of his retirement, for his many contributions to the study of Hawaiian stream gobies and their

remarkable ecosystem. We are also grateful for the logistic support provided by the Hawai'i Division of Aquatic Resources that enabled us to pursue this research, especially Bob Nishimoto, Lance Nishiura, Wade Ishikawa, Troy Sakihara, Troy Shimoda, Tim Shindo, and Darrell Kuamo'o. We also thank Jenn Gander and Katherine Shugart for assistance in image analysis, Joe Travis for suggestions on analysis of selection data, Jerry Husak and two anonymous reviewers for constructive comments on earlier drafts of the article, and Angela Rivera for help assembling figures. Finally, we thank Gabriel Rivera for his effort in organizing this symposium. Research was conducted in accordance with Clemson AUP 40061 and ARC2007-090. We also gratefully acknowledge support of our participation in this symposium provided by the National Science Foundation (IOS-0733441), SICB (DCB, DEE, DIZ and DVM), Vision Research ([www.visionresearch.com](http://www.visionresearch.com)), and EmicroScribe ([www.emicroscribe.com](http://www.emicroscribe.com)).

## Funding

Clemson University Research Investment Fund Award (to R.W.B., M.B.P.); St Cloud State University Faculty Improvement Grant (to H.L.S.); National Science Foundation (IOS-0817794).

*Conflict of interest:* None declared.

## References

- Arnold GP, Weihs D. 1978. The hydrodynamics of rheotaxis in the plaice (*Pleuronectes platessa* L.). *J Exp Biol* 75:147–69.
- Blake RW. 2006. Biomechanics of rheotaxis in six teleost genera. *Can J Zool* 84:1173–86.
- Blob RW, Rai R, Julius ML, Schoenfuss HL. 2006. Functional diversity in extreme environments: effects of locomotor style and substrate texture on the waterfall climbing performance of Hawaiian gobiid fishes. *J Zool* 268:315–24.
- Blob RW, Wright KM, Becker M, Maie T, Iverson TJ, Julius ML, Schoenfuss HL. 2007. Ontogenetic change in novel functions: waterfall climbing in adult Hawaiian gobiid fishes. *J Zool* 273:200–9.
- Brodie ED III. 1992. Correlational selection for color pattern and antipredator behavior in the garter snake *Thamnophis ordinoides*. *Evolution* 46:1284–98.
- Buckley CR, Jackson M, Youssef M, Irschick DJ, Adolph SC. 2007. Testing the persistence of phenotypic plasticity after incubation in the western fence lizard, *Sceloporus occidentalis*. *Evol Ecol Res* 9:169–83.
- Brinsmead J, Fox MG. 2002. Morphological variation between lake- and stream-dwelling rock bass and pumpkinseed populations. *J Fish Biol* 61:1619–38.
- Brönmark C, Miner JG. 1992. Predator-induced phenotypical change in body morphology in crucian carp. *Science* 258:1348–50.
- Carson HL, Clague DA. 1995. Geology and biogeography of the Hawaiian Islands. In: Wagner WL, Funk VA, editors. *Hawaiian biogeography: evolution on a hotspot archipelago*. Washington, DC: Smithsonian Institution Press. p. 14–29.
- Chubb AL, Zink RM, Fitzsimons JM. 1998. Patterns of mtDNA variation in Hawaiian freshwater fishes: the phylogeographic consequences of amphidromy. *J Hered* 89:8–16.
- Daniel TL, Webb PW. 1987. Physical determinants of locomotion. In: Dejours P, Bolis L, Taylor CR, Weibel ER, editors. *Comparative physiology: life in water and on the land*. Padova: Liviana Press. p. 343–69.
- Denny MW. 1993. *Air and water: the biology and physics of life's media*. Princeton, NJ: Princeton University Press.
- DeWitt TJ, Sih A, Wilson DS. 1998. Costs and limits of phenotypic plasticity. *TREE* 13:77–81.
- Domenici P. 2003. Habitat, body design, and the swimming performance of fish. In: Bels VL, Gasc J-P, Casinos A, editors. *Vertebrate biomechanics and evolution*. Oxford: BIOS Scientific Publishers. p. 137–60.
- Domenici P, Turesson H, Brodersen J, Brönmark C. 2008. Predator-induced morphology enhances escape locomotion in crucian carp. *Proc Roy Soc B* 275:195–201.
- Drucker EG, Lauder GV. 2003. Function of pectoral fins in rainbow trout: behavioral repertoire and hydrodynamic forces. *J Exp Biol* 206:813–26.
- Ebenman B. 1992. Evolution in organisms that change their niches during the life cycle. *Am Nat* 139:990–1021.
- Emerson SB, Diehl D. 1980. Toe pad morphology and mechanisms of sticking in frogs. *Biol J Linn Soc* 13:199–216.
- Engleman L. 1996. Discriminant analysis. In: *SYSTAT 10*. Chicago: SPSS. p. I-275–I-326.
- Fitzsimons JM, Zink RM, Nishimoto RT. 1990. Genetic variation in the Hawaiian stream goby, *Lentipes concolor*. *Biochem Syst Ecol* 18:81–3.
- Fitzsimons JM, Nishimoto RT, Yuen AR. 1993. Courtship and territorial behavior in the native Hawaiian stream goby, *Sicyopterus stimpsoni*. *Ichthyol Explor Freshw* 4:1–10.
- Fitzsimons JM, Nishimoto RT. 1995. Use of fish behaviour in assessing the effects of Hurricane Iniki on the Hawaiian island of Kaua'i. *Environ Biol Fish* 43:39–50.
- Fitzsimons JM, Schoenfuss HL, Schoenfuss TC. 1997. Significance of unimpeded flows in limiting the transmission of parasites from exotics to Hawaiian stream fishes. *Micronesica* 30:117–25.
- Fitzsimons JM, McRae MG, Schoenfuss HL, Nishimoto RT. 2003. Gardening behavior in the amphidromous Hawaiian fish *Sicyopterus stimpsoni* (Osteichthyes: Gobiidae). *Ichthyol Explor Freshw* 14:185–91.
- Fuller RC, Baer CF, Travis J. 2005. How and when selection experiments might actually be useful. *Int Comp Biol* 45:391–404.
- Gabriel W, Luttbeg B, Sih A, Tollrian R. 2005. Environmental tolerance, heterogeneity, and the evolution of reversible plastic responses. *Am Nat* 166:339–53.

- Hoerner SF. 1958. Fluid-dynamic drag. Midland Park, New Jersey: Published by the author.
- Imre I, McLaughlin RL, Noakes DLG. 2002. Phenotypic plasticity in brook charr: changes in caudal fin induced by water flow. *J Fish Biol* 61:1171–81.
- Irschick D, Bailey JK, Schweitzer JA, Husak JF, Meyers JJ. 2007. New directions for studying selection in nature: studies of performance and communities. *Physiol Biochem Zool* 80:557–67.
- Janzen FJ, Stern HS. 1998. Logistic regression for empirical studies of multivariate selection. *Evolution* 52:1564–71.
- Julius ML, Blob RW, Schoenfuss HL. 2005. The survival of *Sicyopterus stimpsoni*, an endemic amphidromous Hawaiian gobiid fish, relies on the hydrological cycles of streams: evidence from changes in algal composition of diet through growth stages of fish. *Aquat Ecol* 39:473–84.
- Julius ML. 2007. Why sweat the small stuff: the importance of microalgae in Hawaiian stream ecosystems. *Bishop Mus Bull Cult Environ Stud* 3:183–94.
- Kido MH. 1996. Diet and food selection in the endemic Hawaiian amphidromous goby, *Sicyopterus stimpsoni* (Pisces: Gobiidae). *Environ Biol Fish* 45:199–209.
- Kido MH. 1997. Food relations between coexisting native Hawaiian stream fishes. *Environ Biol Fish* 49:481–94.
- Kier WM, Smith AM. 1990. The morphology and mechanics of octopus suckers. *Biol Bull* 178:126–36.
- Kier WM, Smith AM. 2002. The structure and adhesive mechanism of octopus suckers. *Int Comp Biol* 42:1146–53.
- Keith P. 2003. Biology and ecology of amphidromous Gobiidae of the Indo-Pacific and Caribbean regions. *J Fish Biol* 63:831–47.
- King RB. 1993. Color-pattern variation in Lake Erie water snakes – prediction and measurement of natural selection. *Evolution* 47:1819–33.
- Krzanowski WJ. 2000. Revised Edition. Principles of multivariate analysis. Oxford: Clarendon Press.
- Lande R, Arnold SJ. 1983. The measurement of selection on correlated characters. *Evolution* 37:1210–26.
- Langerhans RB, Layman CA, Langerhans AK, DeWitt TJ. 2003. Habitat-associated morphological divergence in two neotropical fish species. *Biol J Linn Soc* 80:689–98.
- Lee JC. 1982. Accuracy and precision in anuran morphometrics: artifacts of preservation. *Syst Zool* 31:266–81.
- Maie T, Schoenfuss HL, Blob RW. 2007. Ontogenetic scaling of body proportions in waterfall-climbing gobiid fishes from Hawai'i and Dominica: implications for locomotor function. *Copeia* 2007:755–64.
- Martin RF. 1978. Clutch weight/total body weight ratios of lizards (Reptilia, Lacertilia, Iguanidae): preservative induced variation. *J Herpetol* 12:248–51.
- McDowall RM. 2001. Diadromy, diversity and divergence: implications for speciation processes in fishes. *Fish Fisheries* 2:278–85.
- McDowall RM. 2003. Hawaiian biogeography and the islands' freshwater fish fauna. *J Biogeogr* 30:703–10.
- McDowall RM. 2004. Ancestry and amphidromy in island freshwater fish faunas. *Fish Fisheries* 5:75–85.
- McGuigan K, Franklin CE, Moritz C, Blows MW. 2003. Adaptation of rainbow fish to lake and stream habitats. *Evolution* 57:104–18.
- Møller AP. 1996. The cost of secondary sexual characters and the evolution of cost-reducing traits. *Ibis* 138:112–9.
- Mosimann JE, James FC. 1979. New statistical methods for allometry with application to Florida red-winged blackbirds. *Evolution* 33:444–59.
- Neff NA, Marcus LF. 1980. A survey of multivariate methods for systematics. New York: Privately published.
- Nishimoto RT, Fitzsimons JM. 1986. Courtship, territoriality, and coloration in the endemic Hawaiian freshwater goby, *Lentipes concolor*. In: Uyeno T, Arai R, Taniuchi T, Matsuura K, editors. Indo-Pacific fish biology. Proceedings of the Second International Conference on Indo-Pacific fishes. Tokyo: Ichthyological Society of Japan. p. 811–7.
- Nishimoto RT, Fitzsimons JM. 1999. Behavioral determinants of the instream distribution of native Hawaiian stream fishes. In: Séret B, Sire J–Y, editors. Proceedings of the Fifth Indo-Pacific Fish Conference, Nouméa. Paris: Societe Francaise d'Ichthyologie. p. 813–8.
- Nishimoto RT, Kuamo'o DGK. 1997. Recruitment of goby postlarvae into Hakalau Stream, Hawai'i Island. *Micronesica* 30:41–9.
- Niskanen M, Mappes J. 2005. Significance of the dorsal zigzag pattern of *Vipera latastei gaditana* against avian predators. *J Anim Ecol* 74:1091–101.
- Pakkasmaa S, Piironen J. 2001. Water velocity shapes juvenile salmonids. *Evol Ecol* 14:721–30.
- Peres-Neto PR, Magnan P. 2004. The influence of swimming demand on phenotypic plasticity and morphological integration: a comparison of two polymorphic charr species. *Oecologia* 140:36–45.
- Pettersson LB, Brönmark C. 1999. Energetic consequences of an inducible morphological defense in crucian carp. *Oecologia* 121:12–8.
- Pettersson LB, Hedenström A. 2000. Energetics, cost reduction, and functional consequences of fish morphology. *Proc R Soc Lond B* 267:759–64.
- Radtke RL, Kinzie RA, Folsom SD. 1988. Age at recruitment of Hawaiian freshwater gobies. *Environ Biol Fish* 23: 205–13.
- Relyea RA. 2003. Predators come and predators go: the reversibility of predator-induced traits. *Ecology* 84:1840–8.
- Reznick DN, Ghalambor CK. 2005. Selection in nature: experimental manipulations of natural populations. *Int Comp Biol* 45:456–62.
- Rivera G. 2008. Ecomorphological variation in shell shape of the freshwater turtle *Pseudemys concinna* inhabiting different aquatic flow regimes. *Int Comp Biol* doi:10.1093/icb/icn088.
- Rohlf FJ, Sokal RR. 1995. Statistical tables. 3rd Edition. New York: WH Freeman.

- Schoenfuss HL, Blanchard TA, Kuamo'o DGG. 1997. Metamorphosis in the cranium of postlarval *Sicyopterus stimpsoni*, an endemic Hawaiian stream goby. *Micronesica* 30:93–104.
- Schoenfuss HL, Blob RW. 2003. Kinematics of waterfall climbing in Hawaiian freshwater fishes (Gobiidae): vertical propulsion at the aquatic-terrestrial interface. *J Zool* 261:191–205.
- Schoenfuss HL, Julius ML, Blob RW. 2004. Colonization of a recent, volcanically formed freshwater habitat: an example of primary succession. *Ichthyol Explor Freshw* 15:83–90.
- Schoenfuss HL, Blob RW. 2007. The importance of functional morphology for fishery conservation and management: applications to Hawaiian amphidromous fishes. *Bishop Mus Bull Cult Environ Stud* 3:125–41.
- Swain DP. 1992. Selective predation for vertebral phenotype in *Gasterosteus aculeatus*: reversal in the direction of selection at different larval sizes. *Evolution* 46:998–1013.
- Tate DC. 1997. The role of behavioral interactions of immature Hawaiian stream fishes (Pisces: Gobiodei) in population dispersal and distribution. *Micronesica* 30:51–70.
- Vogel S. 1994. *Life in moving fluids: the physical biology of flow*. 2nd Edition. Princeton, NJ: Princeton University Press.
- Walker JA. 1997. Ecological morphology of lacustrine threespine stickleback *Gasterosteus aculeatus* L. (Gasterosteidae) body shape. *Biol J Linn Soc* 61:3–50.
- Webb PW. 1984. Body form, locomotion, and foraging in aquatic vertebrates. *Am Zool* 24:107–20.
- Webb PW. 1988. Simple physical principles and vertebrate aquatic locomotion. *Am Zool* 28:709–25.
- Webb PW. 1989. Station-holding by three species of benthic fishes. *J Exp Biol* 145:303–20.
- Zink RM, Fitzsimons JM, Dittmann DL, Reynolds DR, Nishimoto RT. 1996. Evolutionary genetics of Hawaiian freshwater fish. *Copeia* 1996:330–5.